

Wood Truss Gable End Frames

By Agron Gjinolli, P.E. and Jim Vogt, P.E.

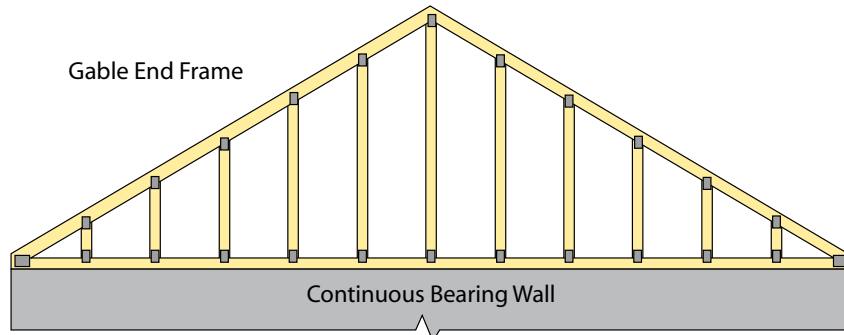

Figure 1: Example of a non-structural gable end frame with continuous bearing along the entire span.

Metal plate connected wood trusses (referred herein as “trusses”) are used in the roofs of most residential and many light commercial buildings constructed in the United States today. An important advantage of trusses is that they can be designed and built to virtually any imaginable configuration and profile, providing simple solutions to complicated framing situations.

The gable end frame is a prime example of how trusses and other components can simplify the framing process. Gable end frames are most often used directly above the non-truss-bearing end walls of a building, and save the contractor the time and expense of field framing the end wall to match the roof slope. However, it is imperative to remember that a gable end frame is an integral structural element of the gable end wall and must be incorporated into the wall design in order to function properly. Confusion sometimes exists as to how much of this “incorporation” is provided by the truss manufacturer and how much must be provided by the building designer. This article reviews the basic design considerations used by the truss industry for gable end frames, and discusses several items that must be considered by the building designer to ensure the

successful integration of the gable end frame into the building structure.

Basic Design Considerations for Gable End Frames

A gable end frame is a manufactured component used to complete the end wall of a building. Most gable end frames are designed to have continuous support along their entire span. The truss industry refers to this as a *non-structural* gable end frame in that the component is not designed to transfer load from bearing wall to bearing wall across a span. The web members in a non-structural gable end frame are oriented vertically (Figure 1) as opposed to the triangulated web members in a typical truss.

Gable end frames can also be designed to carry load over openings in the end wall for the entire span or a portion of the span. These are referred to as *structural* gable end frames and contain both diagonal and vertical web members (Figure 2).

Non-structural gable end frames are designed to receive vertical loads (i.e., gravity and/or uplift) applied within the plane of the frame and to transfer these loads to the continuous bearing

below. The vertical web members in these frames serve as “wall studs” and are oriented with their narrow face perpendicular to the plane of the wall. These web members are typically spaced at 24 inches on center, but may also be spaced at 16 or 12 inches on center. The web members function as vertical load carrying members as well as attachment members for sheathing and other end wall coverings (e.g., vinyl siding).

If the vertical web members are tall enough, and the vertical loads they must support are large enough, web member reinforcement such as L, T, U, or Scab reinforcement (Figure 3) may be required to prevent column buckling of web members due to the vertical loads assumed in the design of the frame. The locations, type, and attachment of this reinforcement are provided on the truss design drawing for the gable end frame. The truss design drawing will also include gravity and uplift reactions for the gable end frame based on the design loads for which the frame has been designed. (An example of a truss design drawing is included in the on-line version of this article.)

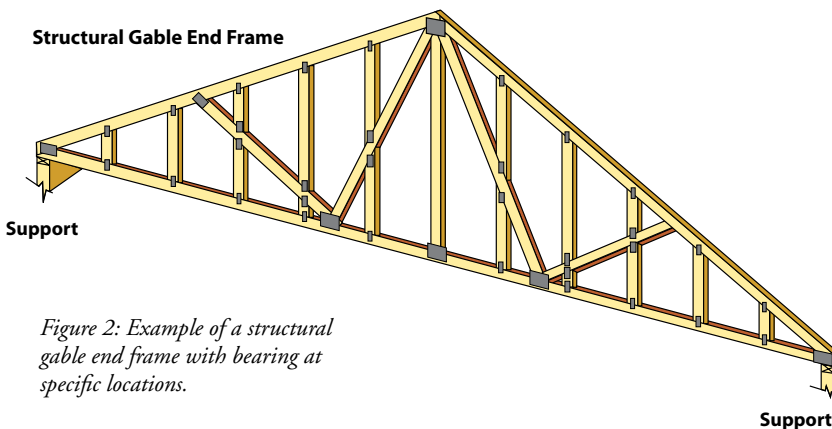

Figure 2: Example of a structural gable end frame with bearing at specific locations.

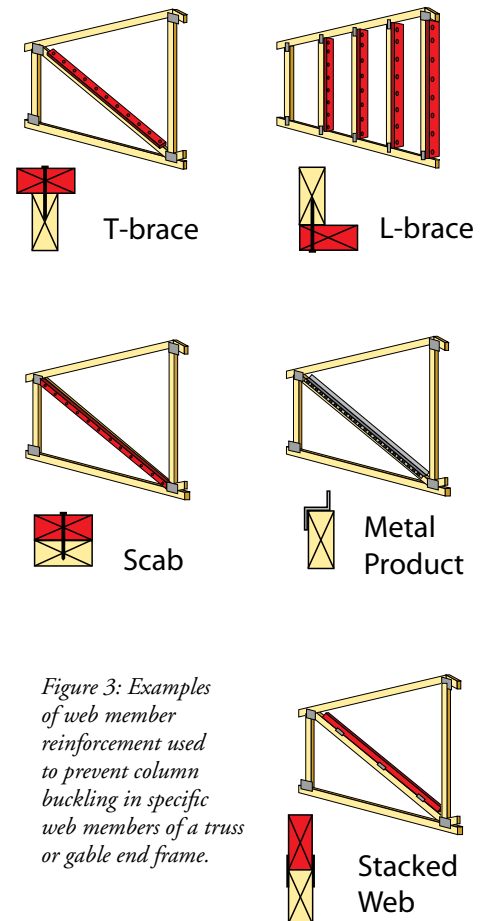

Figure 3: Examples of web member reinforcement used to prevent column buckling in specific web members of a truss or gable end frame.

Key Terminology

BCSI: Guide to Good Practice for Handling, Installing, Restraining & Bracing of Metal Plate Connected Wood Trusses jointly produced by WTCA – Representing the Structural Building Components Industry and Truss Plate Institute.

Building Designer: Owner of the building or the person that contracts with the owner for the design of the framing structural system, and/or who is responsible for preparation of construction documents. When mandated by legal requirements, the building designer shall be a registered design professional.

Construction Documents: Written, graphic, and pictorial documents prepared or assembled for describing the design (including the framing structural system), location and physical characteristics of the elements of a building necessary to obtain a building permit and construct a building.

Diagonal Bracing: Structural member installed at an angle to a truss chord or web member and intended to temporarily and/or permanently stabilize truss member(s) and/or truss(es) (See *BCSI-B1, BCSI-B2, BCSI-B3, BCSI-B7, and BCSI-B10*).

Lateral Restraint: Also known as a continuous lateral brace or CLB. A structural member installed at right angles to a chord or web member of a truss to reduce the laterally unsupported length of the truss member (See *BCSI-B1, BCSI-B2, BCSI-B3, BCSI-B7, and BCSI-B10*).

Permanent Building Stability Bracing: Lateral force resisting system for the building that resists forces from gravity, wind, seismic and/or other loads.

Permanent Individual Truss Member Restraint: Restraint that is used to prevent local buckling of an individual truss chord or web member due to the axial forces in the individual truss member (See *BCSI-B2 and BCSI-B3*).

Truss: Individual metal plate connected wood component manufactured for the construction of a building.

Truss Design Drawing: Written, graphic and pictorial depiction of an individual truss.

Truss Designer: Individual responsible for the preparation of the truss design drawings.

Truss Manufacturer: Individual engaged in the fabrication of trusses.

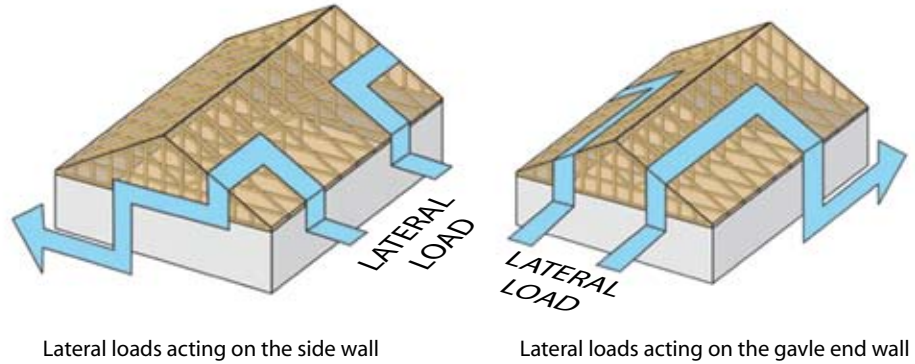

Figure 4: Typical lateral load path through the gable end of a building.

Additional Design Considerations for Gable End Frames

In service, gable end frames also experience lateral loads applied both parallel and perpendicular to their plane from wind and/or seismic events (*Figure 4*).

Gable end frames are typically not designed to resist these loads, but rely on properly designed and installed structural sheathing, lateral restraint, diagonal bracing, and connections to adequately transfer these loads to the permanent building stability bracing for the building.

The building designer, knowing the intended flow of loads for the entire building, is best qualified to take the resultant loads from the gable end frame and transfer them safely through the structure. Many building designers include gable end bracing details in the construction documents for the product and some prescriptive details are available as well. (*Examples of end bracing and prescriptive details are included in the on-line version of this article.*)

To assist the building designer in determining the bracing requirements to transfer lateral loads from the gable end frame into the roof and/or ceiling diaphragm, many truss designers provide standard design tables and details based on typical design assumptions

used by building designers. (*Example is included in on-line version of this article.*) These details provide a variety of options for restraining and bracing web members in a gable end frame against lateral loads applied perpendicular to the frame. Options vary by design load assumptions, web spacing, and web length, and may include individual web member reinforcement, horizontal bracing, and/or diagonal bracing (*Figure 5a and 5b*). These standard tables and details do some of the work for the building designer with respect to incorporating the gable end frame into the overall design of the structure, but they do not take the place of a complete and necessary flow of loads analysis by the building designer.

Some building codes and construction standards include general prescriptive requirements concerning gable end wall bracing. For example, Section 2304.3.4 of the *2004 Florida Building Code (FBC)* states the following:

2004 FBC 2304.3.4 Gable End Wall Bracing.

2394.3.4.1 General. Gable endwalls shall be structurally continuous between points of lateral support.

2394.3.4.2 Cathedral endwalls. Gable endwalls adjacent to cathedral ceiling shall be structurally continuous from the uppermost floor to the ceiling diaphragm or to the roof diaphragm.

continued on page 56

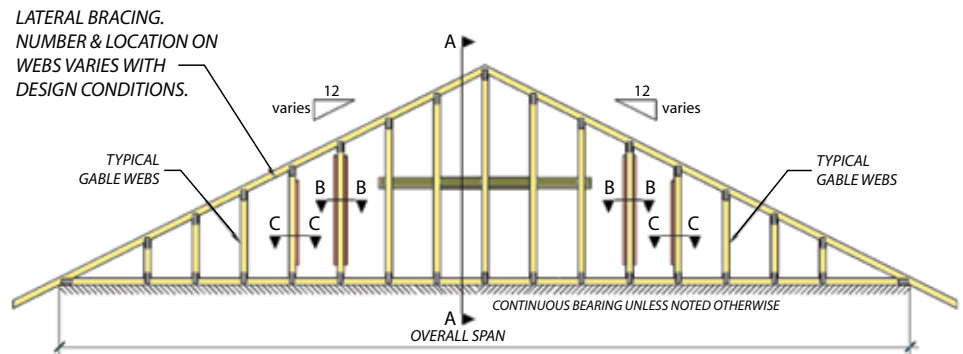

Figure 5a (above) and 5b (page 56): Examples of web member reinforcement and bracing options used to brace gable end frames against lateral loads applied perpendicular to the frame.

2394.3.4.3 Full height studs.

Full height studs may be sized using the bracing at a ceiling diaphragm for determining stud length requirements.

A similar provision is provided in Section 3.4.1.1.2 of the 2001 *Wood Frame Construction Manual (WFCM)*, which is referenced in Section R301.2.1.1 of the 2006 *International Residential Code®*.

3.4.1.1.2 Stud Continuity.

Studs shall be continuous between horizontal supports, including but not limited to girders, floor diaphragms assemblies, ceiling diaphragm assemblies, and roof diaphragm assemblies...

These requirements are based on sound engineering and framing practices aimed at ensuring that there is an adequate lateral load path through the structure. These provisions prevent framing practices in which a flat bottom chord gable end frame is used with adjacent trusses that have sloped bottom chords (*Figure 6*). This condition creates a hinge in the end wall/gable end frame interface that is below the ceiling plane support. Adequate bracing of this condition is difficult if not impossible.

As mentioned earlier, gable end frames experience lateral loads applied parallel and perpendicular to their plane from wind and/or seismic events, and potentially the accumulation of buckling forces of truss web members.

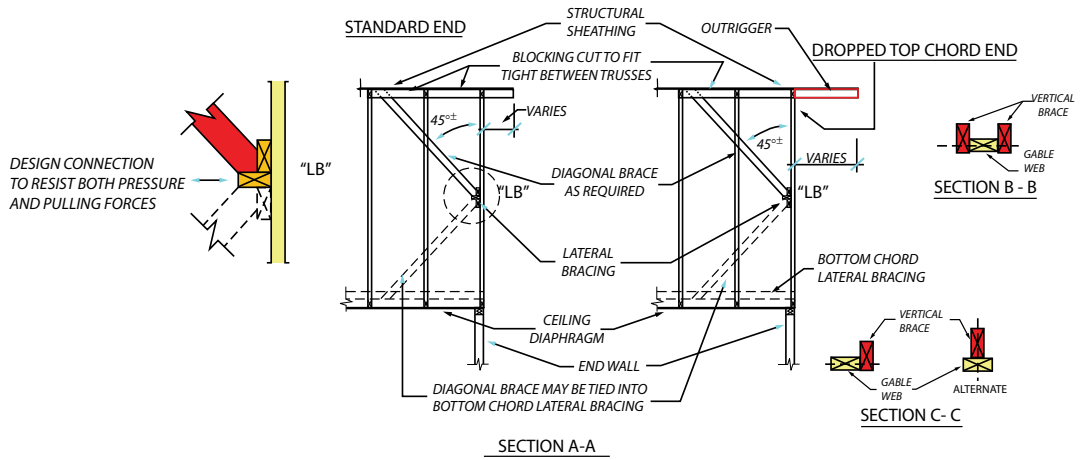

Figure 5b: Additional examples of web member reinforcement and bracing options used to brace gable end frames against lateral loads applied perpendicular to the frame. (see figure 5a on page 55).

As an example, two similar structures (with the same geometry and heights) under wind loads acting perpendicular to the gable end walls were analyzed. One structure had a flat bottom chord gable end frame, while the other analyzed structure had a gable end frame that matched the adjacent scissor truss geometry. *Figure 7* illustrates the stress concentration on the flat bottom chord gable end frame used with adjacent scissor trusses. The three-dimensional analysis of the structure when wind acts perpendicular to the gable end wall shows stresses and deflections that are considerably higher than when the gable end frame matches the adjacent scissor truss geometry (*Figure 8*), and is supported laterally by the ceiling diaphragm.

Summary

Metal plate connected gable end frames are widely used above the end walls of a building to save the contractor the time and expense of having to field frame the end wall to match the roof slope. The gable end frame is an integral structural element of the gable end wall assembly and must be incorporated into the overall wall and building design in order to properly transfer loads to the foundation.

Most gable end frames are designed to have continuous support along their entire span and are referred to by the industry as a non-structural gable end frame. The non-structural gable end frames are designed to receive vertical loads (i.e., gravity and/or uplift) applied within the plane of the frame and to transfer these loads to the continuous bearing below. During normal non-wind loading, this is a reasonable presumption.

However, in service, gable end frames also experience lateral loads applied both parallel and perpendicular to their plane from wind and/or seismic events, as well as the possible accumulation of buckling forces of truss web members. Gable end frames are typically not designed to resist these loads. In order to support and transfer lateral loads to the permanent building stability bracing, properly designed and installed structural sheathing, lateral restraint, diagonal bracing, and related connections are required. ■

The on-line version of this article contains additional graphics and examples. Please visit www.STRUCTUREmag.org.

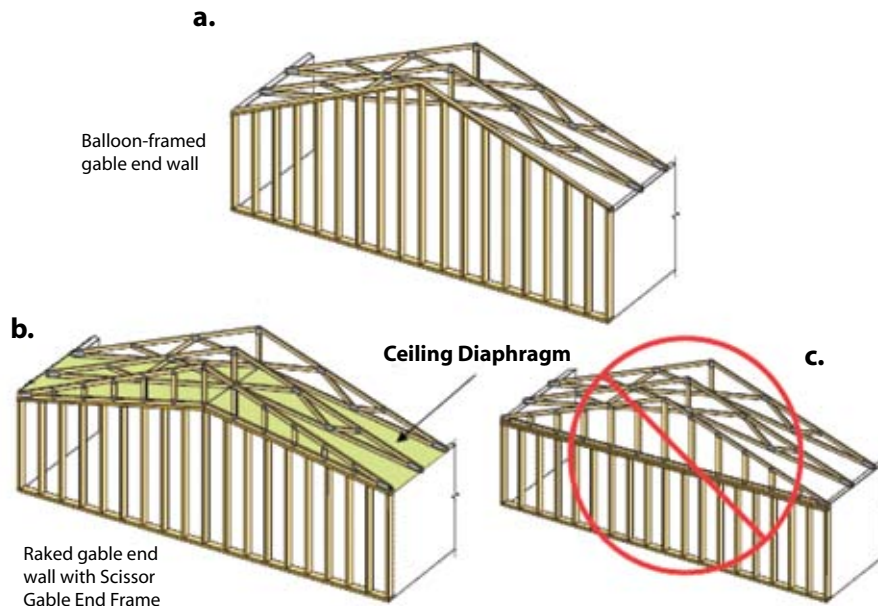

Figure 6: Graphics (a) and (b) are examples of gable end walls that are structurally continuous between the supports, while graphic (c) shows the structural discontinuity and it is not recommended as this configurations creates a hinge at the interface between the gable end frame, which is below the ceiling diaphragm.

Mr. Gjinolli is a Project Engineer with Qualtim, Madison, WI. Mr. Gjinolli has 23+ years of combined experience in structural analysis and design, failure analysis, forensic structural engineering and research and teaching at the university level in the area of structural engineering. Mr. Gjinolli has authored or co-authored several publications pertaining to wood engineering and design, precast and prestressed concrete, failure analysis and forensic structural investigations, and has presented or co-presented numerous papers on wood engineering at various industry conferences and symposiums in the US and Europe. He can be reached at agjinolli@qualtim.com.

Mr. Vogt serves as the Director of Technical Services at Qualtim. Mr. Vogt has over 19 years experience in the fields of engineering, construction, manufacturing, quality assurance, testing, and wood science and technology. He can be reached at jvogt@qualtim.com.

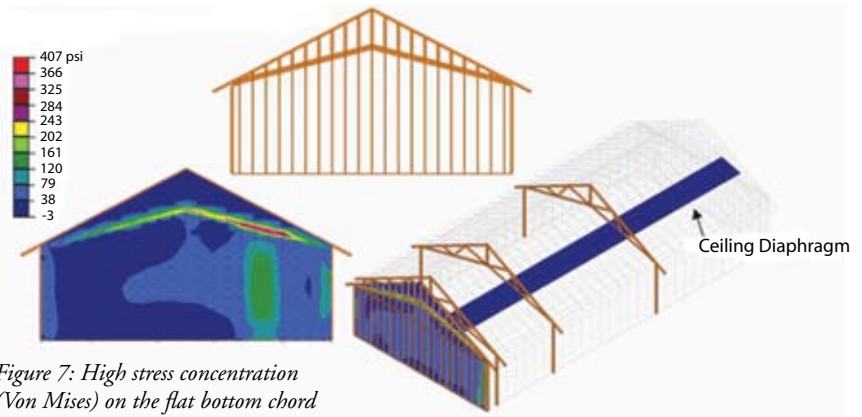

Figure 7: High stress concentration (Von Mises) on the flat bottom chord gable end frame used with adjacent scissor trusses due to wind acting perpendicular to the gable end wall. High stresses and deflections creates potential for hinge development at the interface between the bottom chord of the gable end truss and bearing wall below.

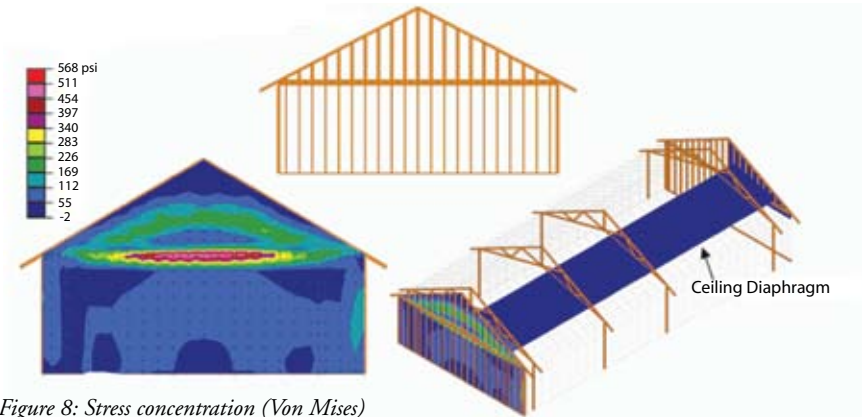

Figure 8: Stress concentration (Von Mises) and deflections are considerably lower in the case when the gable end frame matches the adjacent scissor truss geometry and is supported laterally by the ceiling diaphragm.

ADVERTISEMENT – For Advertiser Information, visit www.STRUCTUREmag.org

Confidence Delivered.

APA Product Reports® give you the confidence needed to design and specify APA stamped engineered wood products in conformance with codes and standards. Report evaluations are based on test data or analysis performed at APA's Research Center by experienced engineers and scientists, specializing in engineered wood products, codes and standards.



For all 25 Product Reports, visit www.apawood.org

APA
THE ENGINEERED
WOOD ASSOCIATION